

# Hartmetall-Zentrierspitzen, volle Spitze 60° mit Abdrückgewinde

## Form GE – GV – GZ – GR

Rundheitstoleranz  $\ominus \leq 0,8 \mu\text{m}$ . Morsekegel zum Schutz vor Beschädigung gehärtet.

| Form | Morsekegel | Bestell-Nr. | D    | d2   | LC    | L       | G       |
|------|------------|-------------|------|------|-------|---------|---------|
| GE   | 2          | 2852        | 7    | 18   | 48    | 112     | M22x1,5 |
|      | 3          | 2853        | 11   | 24,1 | 57    | 138     | M27x1,5 |
|      | 3          | 2853.18     | 18   | 24,1 | 57    | 138     | M27x1,5 |
|      | 4          | 2854        | 14   | 31,6 | 72,5  | 175     | M36x1,5 |
|      | 4          | 2854.18     | 18   | 31,6 | 72,5  | 175     | M36x1,5 |
|      | 4          | 2854.18-200 | 18   | 31,6 | 97,5  | 200     | M36x1,5 |
|      | 5          | 2855        | 18   | 44,7 | 87,5  | 217     | M48x1,5 |
|      | 5          | 2855.18-250 | 18   | 44,7 | 120,5 | 250     | M48x1,5 |
|      | 6          | 2856        | 18   | 63,8 | 108   | 290     | M68x1,5 |
| 6    | 2856.35    | 35          | 63,8 | 108  | 290   | M68x1,5 |         |

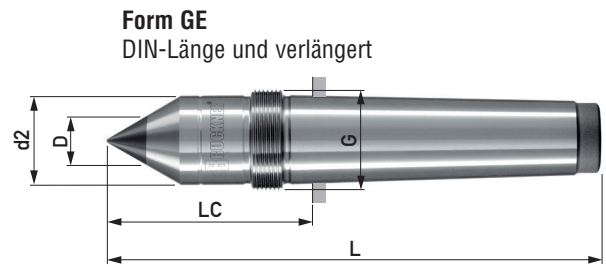

| Form | Morsekegel | Bestell-Nr.  | D    | LC    | L   | G       |
|------|------------|--------------|------|-------|-----|---------|
| GV   | *2         | 2852.18V     | 18   | 48    | 112 | M22x1,5 |
|      | 3          | 2853.24V     | 24,1 | 57    | 138 | M27x1,5 |
|      | 4          | 2854.32V     | 31,6 | 72,5  | 175 | M36x1,5 |
|      | 4          | 2854.32V-200 | 31,6 | 97,5  | 200 | M36x1,5 |
|      | 5          | 2855.45V     | 44,7 | 87,5  | 217 | M48x1,5 |
|      | 5          | 2855.45V-250 | 44,7 | 120,5 | 250 | M48x1,5 |
|      | **6        | 2856.64V     | 63,8 | 108   | 290 | M68x1,5 |

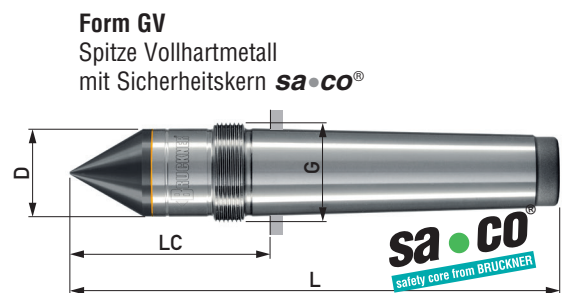

**i**

\* ohne Sicherheitskern, Hartmetall kegelförmig eingelötet  
\*\* ohne Sicherheitskern, Hartmetallkappe mit Kern aus Trägermaterial

| Form | Morsekegel | Bestell-Nr. | D  | d  | d2 | LC | L   | G       |
|------|------------|-------------|----|----|----|----|-----|---------|
| GZ   | 3          | 2853.32x10  | 32 | 10 | 38 | 57 | 138 | M27x1,5 |



**i**

| Form | Morsekegel | Bestell-Nr. | D  | d  | LC   | L   | G       |
|------|------------|-------------|----|----|------|-----|---------|
| GR   | 3          | 2853.45x25  | 45 | 25 | 57   | 138 | M27x1,5 |
|      | 4          | 2854.45x25  | 45 | 25 | 72,5 | 175 | M36x1,5 |
|      | 4          | 2854.60x40  | 60 | 40 | 72,5 | 175 | M36x1,5 |
|      | 5          | 2855.45x25  | 45 | 25 | 87,5 | 217 | M48x1,5 |
|      | 5          | 2855.60x40  | 60 | 40 | 87,5 | 217 | M48x1,5 |

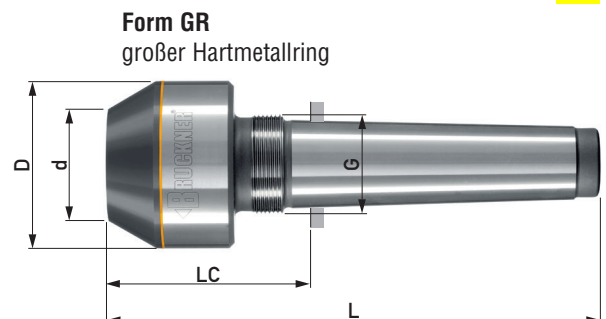

| Abdrückmutter DIN 807 |          |      |     |
|-----------------------|----------|------|-----|
| Bestell-Nr.           | G        | LM   | SW  |
| M252                  | M 22x1,5 | 15,5 | 32  |
| M253                  | M 27x1,5 | 17,5 | 41  |
| M254                  | M 36x1,5 | 21   | 55  |
| M255                  | M 48x1,5 | 23   | 75  |
| M256                  | M 68x1,5 | 25,5 | 100 |

